

# Introduction to Logic

PHI 1113 01  
Fall 2015

MWF 9-9:50 AM

ETHRDG 223A

Mississippi State  
University

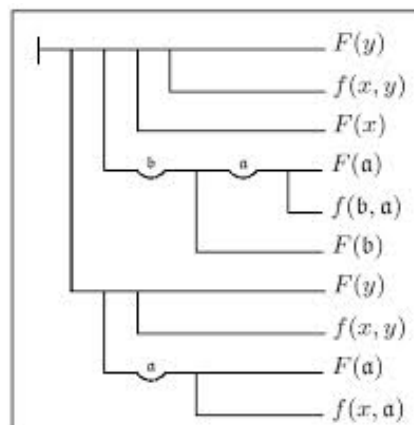

Theorem 71 from *Begriffsschrift*

## Course Description and Objectives

In this course we will look at the study of logic

This is an introduction to formal deductive reasoning—drawing inferences, distinguishing good arguments from bad ones, making one’s way from assumptions to their consequences. By using a formal language and natural deduction system, we will symbolize arguments, determine the validity of arguments, derive conclusions from their premises, and develop a methodology for determining whether an argument is valid or invalid. We will study the logic of expressions in English including ‘not’, ‘if’, ‘and’, ‘or’, ‘if and only if’, ‘all’, and ‘some’.

At the end of this course, as a student, you should be able to do the following:

- Recognize different notions of meaning in language.
- Identify specious forms of reasoning.
- Identify the complexity and structure of English by symbolizing statements and arguments in propositional and first-order logical languages.
- Understand the difference between syntactic and semantic methods in logic.
- Demonstrate the validity of ar-

guments through a natural deduction system.

- Calculate the validity or invalidity of symbolized arguments.
- Show the invalidity of symbolized arguments by presenting a counter-example (model).

### What’s in this syllabus?

|                         |   |
|-------------------------|---|
| Learning Outcomes       | 1 |
| Course Requirements     | 2 |
| Grading                 | 2 |
| Expectations            | 2 |
| Schedule                | 3 |
| Student w/ Disabilities | 4 |
| Honor Code              | 4 |
| Title IX                | 4 |

**Website:** Aplia/CengageBrain

**Required text:** Patrick J. Hurley (2015) *A Concise Introduction to Logic*, 12<sup>th</sup> Edition. Stamford CT: Cengage Learning.

**Required software:** Aplia (should be included with your textbook)

### Course Details



Instructor: Dr. David Spewak

Office: Etheredge 228C  
 Email: dspewak@philrel.msstat.edu  
 Office Hours: MW 1-2PM & by appt.

## Course Requirements

This course involves reading, writing, and group discussion. You will need to put in consistent effort throughout the entire semester. You will need to speak up in class and demonstrate active learning, not passive absorption.

**Participation (10%)** You are expected to attend lectures prepared, i.e. having done the reading and ready to discuss the material. Your participation grade will be based on how you take part in class discussions. Just showing up for class will not result in getting your class participation grade.

**Homework (30%)** You will have regular weekly homework assignments due Sunday night. This will be done through the **Aplia** online learning component. You will find

the homework assignments online through Aplia. Learning logic is like learning a skill. You cannot learn this material in one sitting. Instead you should practice a little each day. This is where the homework comes in. Though the homework is due on Sundays, you should work on it little by little each day.

**Exams (60%)** We will have a total of 3 exams. The last exam will take place during the designated final exam period. The midterm exams will be worth 15% each and the final exam will be worth 30% of your course grade. The second midterm and the final exam will be open-book and open-note. Exam dates are listed below. **There are no makeup exams.**

### Grading Scale:

|                     |     |                         |
|---------------------|-----|-------------------------|
| Participation       | 10% |                         |
| Homework            | 30% |                         |
| First Midterm Exam  | 15% | Friday 4 September 2015 |
| Second Midterm Exam | 15% | Monday 19 October 2015  |
| Final Exam          | 30% | Monday 7 December 2015  |

NB There will be no extra-credit available.

NB\* All exams must be completed in order to pass the course.

### Classroom Expectations

**Cheating:** The *minimum penalty* for cheating or plagiarism is a *failure in the class* with the grade of *XF*. It's not worth it, so don't do it. If you have any questions, please ask me, I'm here to help.

**Classroom:** I expect that everyone will maintain a classroom conducive to learning. I like an informal atmosphere, but it must be orderly. Thus, everyone is expected to behave with basic politeness, civility,

and respect for others. In particular, talking in class is ok if it's part of a class discussion or with me. Private communications are not, especially during quizzes and tests. Neither are reading extraneous materials, using cell phones, or sleeping.

**Use of Electronics:** I do not allow the use of electronic devices in class. This includes, but is not limited to, cellphones, tablets, and computers. Any unauthorized use of one of these devices in class will result in a quiz on the most recent reading for the

entire class.<sup>1</sup>

**Suggestions:** Suggestions for improvement are welcome at any time. Any concern about the course should be brought first to my attention.



<sup>1</sup>Evidence in favor of pen and paper note-taking is discussed [here](#).

### Tentative Schedule

| Date  | Topic                                   | What to Read          | Fallacy (CH 3)                      |
|-------|---|-----------------------|-------------------------------------|
| 8/17  | First Day                               | No reading            |                                     |
| 8/19  | Introduction                            | pgs. 1-7              |                                     |
| 8/21  | Recognizing Arguments                   | pgs. 14-25            |                                     |
| 8/24  | Deduction and Induction                 | pgs. 33-40            |                                     |
| 8/26  | Deduction and Induction cont.           |                       |                                     |
| 8/28  | Truth and Argument Form                 | pgs. 44-54            |                                     |
| 8/31  | Proving Invalidity                      | pgs. 59-64            |                                     |
| 9/2   | Review/Practice                         | No new reading        |                                     |
| 9/4   | <b>Exam 1</b>                           |                       |                                     |
| 9/7   | No Class (Labor Day)                    |                       |                                     |
| 9/9   | Symbols and Translation                 | pgs. 316-325          |                                     |
| 9/11  | Practice                                |                       | (1) Appeal to Force                 |
| 9/14  | Truth Functional Meaning                | pgs. 330-339; 342-348 | (2) Appeal to Pity                  |
| 9/16  | Arguments                               | pgs. 351-354          | (3) Appeal to the People            |
| 9/18  | Practice                                |                       | (4) Against the Person              |
| 9/21  | Indirect Truth Tables                   | pgs. 358-365          | (6) Straw Man                       |
| 9/23  | Invalidity                              |                       | (8) Red Herring                     |
| 9/25  | Practice                                |                       | (9) Appeal to Unqualified Authority |
| 9/28  | Rules of Imp. (MP and MT)               | pgs. 388-395          | (10) Appeal to Ignorance            |
| 9/30  | Rules of Imp. (HS and DS)               | pgs. 388-395          | (11) Hasty Generalization           |
| 10/2  | Practice                                |                       | (12) False Cause                    |
| 10/5  | No Class (Fall Break)                   |                       |                                     |
| 10/7  | Rules of Imp. (CD, Simp, Conj, and Add) | pgs. 401-406          | (14) Weak Analogy                   |
| 10/9  | Practice                                |                       | (15) Begging the Question           |
| 10/12 | Rules of Rep. (DM and Com)              | pgs. 411-417          | (16) Complex Question               |
| 10/14 | Rules of Rep. (Assoc, Dist, and DN)     | pgs. 411-417          | (17) False Dicotomy                 |
| 10/16 | Practice                                |                       |                                     |
| 10/19 | <b>Exam 2</b>                           |                       |                                     |
| 10/21 | Rules of Rep. (Trans, Impl, and Equiv)  | pgs. 424-429          | (19) Equivocation                   |
| 10/23 | Practice                                |                       | (20) Amphiboly                      |
| 10/26 | Rules of Rep.                           | pgs. 424-429          | (21) Composition                    |
| 10/28 | Conditional Proof                       | pgs. 437-441          | (21) Division                       |
| 10/30 | Practice                                |                       |                                     |
| 11/2  | Indirect Proof                          | pgs. 443-447          |                                     |
| 11/4  | Logical Truths                          | pgs. 449-451          |                                     |
| 11/6  | Practice                                |                       |                                     |
| 11/9  | Predicate Logic Symbolization           | pgs. 454-461          |                                     |
| 11/11 | Rules of Inf.                           | 464-472               |                                     |
| 11/13 | Practice                                |                       |                                     |
| 11/16 | Quantifier Negation                     | pgs. 477-480          |                                     |
| 11/18 | Review                                  |                       |                                     |
| 11/20 | Practice                                |                       |                                     |
| 11/23 | Review                                  |                       |                                     |
| 11/30 | Last Day of Class                       |                       |                                     |
| 12/7  | Final Exam                              | 8-11AM                |                                     |

**Students with Disabilities:** If you need accommodations, please speak to me in advance and make arrangements with Student Support Services, 01 Montgomery Hall, 662-325-3335, or at <http://www.sss.msstate.edu/disabilities/>.

**Student Honor Code:** Mississippi State has an approved Honor Code that applies to all students. The code is as follows: "As a Mississippi State University student, I will conduct myself with honor and integrity at all times. I will not lie, cheat, or steal, nor will I accept the actions of those who do." Upon accepting admission to Mississippi State University, a student immediately assumes a commitment to uphold the Honor Code, to accept responsibility for learning, and to follow the philosophy and rules of the Honor Code. Student will be required to state their commitment on examinations, research papers, and other academic work. Ignorance of the rules does not exclude any member of the MSU community from the requirements or the processes of the Honor Code. For additional information, please visit: <http://www.honorcode.msstate.edu/policy/>.

**Title IX:** MSU is committed to complying with Title IX, a federal law that prohibits discrimination, including violence and harassment, based on sex. This means that MSU's educational programs and activities must be free from sex discrimination, sexual harassment, and other forms of sexual misconduct. If you or someone you know has experienced sex discrimination, sexual violence and/or harassment by any member of the University community, you are encouraged to report the conduct to MSU's Director of Title IX/EEO Programs at 325-8124 or by e-mail to [titleix@msstate.edu](mailto:titleix@msstate.edu). Additional resources are available at <http://www.msstate.edu/web/security/title9-12.pdf>, or at <http://students.msstate.edu/sexualmisconduct/>.